



PRODUCT CATALOGUE



SMART
TECHNOLOGY

www.smartstator.com





ABOUT US

Smart technology was founded in 2014. Combining its experience and quality, it develops and manufactures gypsum plaster spraying machines and mixing machines rotor stator and spare parts for the construction industry. In addition to its leadership in the Turkish market, it has a presence in 14 countries and European countries.

www.smartstator.com





SM-04

Standard Spray Plaster Machines

Discover our spraying
machines for powder products.

TECHNICAL DATA: Standard Series

Pumping capacity	Average 22 lt. 1. Min.
With different pump	6-20 l/min
Pumping pressure	30 bar
Pumping distance	Horizontal max. 20 m
Operating	380 V. 50-60 Hz
Mixer Engine	5,5 kW
Wheel Engine	0,55 kW
The main power cable	4*4 ttr
Protection Insurance	25 A
Water connection	3/4"
Water pressure	Minimum 2,5 bar
Compressor capacity	400 V. , 3PH, 50 HZ, 0.9 kW, 250 lt / min.
Remote control	Pnomatic
The pumping hose	ø 25 mm
Vessel capacity	150 kg
Dimensions (L/W/H)	1350/750/1550
Loading height	92 cm
Length	180 cm
Width	75 cm
Height	162 cm
Weight	300 kg



TECHNICAL DATA: Monophase Series

Pumping capacity	Average 17 lt. 1. Min.
With different pump	6-17 l/min
Pumping pressure	20 bar
Pumping distance	Horizontal max. 15 m
Operating	220 V. 50-60 Hz
Mixer Engine	4 kW
Wheel Engine	0,55 kW
The main power cable	4*4 ttr
Protection Insurance	32 A
Water connection	3/4"
Water pressure	Minimum 2,5 bar
Compressor capacity	220 V. , 3 PH, 50 HZ, 0,9 kW, 250 lt / min.
Remote control	Pnomatic
The pumping hose	ø 25 mm
Vessel capacity	150 kg
Dimensions (L/W/H)	1350/750/1550
Loading height	92 cm
Length	180 cm
Width	75 cm
Height	162 cm
Weight	300 kg

SM-02

Monophase Spray Plaster Machines

Discover our spraying
machines for powder products.



SM-07 Premium Spray Plaster Machines

Discover our spraying machines for powder products.

TECHNICAL DATA: Premium Series

Pumping capacity	Average 27 lt. 1. Min.
With different pump	6-32 l/min
Pumping pressure	40 bar
Pumping distance	Horizontal max. 30 m
Operating	380 V. 50-60 Hz
Mixer Engine	Nord-Germany 400 V, 3 pH, 50 HZ, 5.5 kW, 400 rpm
Wheel Engine	0,55 kW
The main power cable	4*4 ttr
Protection Insurance	25 A
Water connection	3/4"
Water pressure	Minimum 2,5 bar
Compressor capacity	Koellmann-Germany 400 V. , 3 pH, 50 HZ, 0.9 kW, 250 lt / min.
Remote control	Pnomatic
The pumping hose	ø 25 mm
Vessel capacity	150 kg
Dimensions (L/W/H)	1350/750/1550
Loading height	92 cm
Length	180 cm
Width	75 cm
Height	162 cm
Weight	300 kg

ROTOR / STATOR



SM-21
Smart D6-3 Twister



SM-22
Smart D6-3



SM-23
Smart D8-1.5



SM-24
SprayTech D8-2



SM-25
Smart D7-2.5



SM-26
Smart D6-3.5



SM-27
Smart Eco-220

SM-30
Eco-220



SM-31
D8-1,5



SM-32
D8-2



SM-33
D7-2,5



SM-34
D6-3



SM-35
D6-3,5



MOTORS

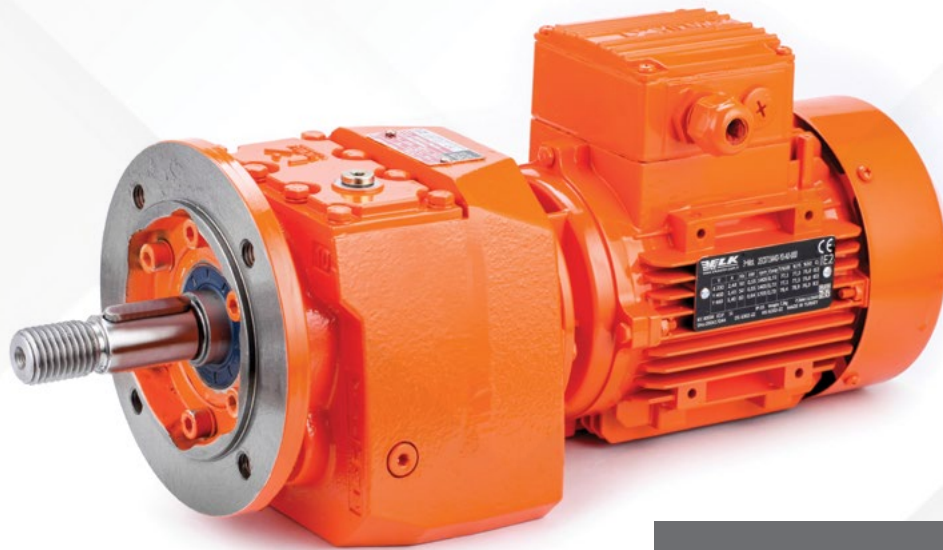

SM-40
Wheel Engine

SM-41
Mixer Engine



SM-42
Water Engine



SM-43
Air Compressor



SM-50
Gasket 25 mm



SM-51
Gasket 22 mm



SM-52
Cleaning Ball



SM-53
Flow Meter



SM-54
Spray Head 14 mm



SM-55
Flow Meter Record



SM-56
Regulator Cover



SM-57
Regulator Key



SM-58
Plumb



SM-60
Regulator



SM-59
Filter



SM-61
Pressure Switch



SM-62
Spray Head 12 mm



SM-63
Spray Head 14 mm



SM-64
Lower Flange



SM-65
Spray Gun - Short



SM-66
Spray Gun - Long



SM-67
Curved Head - Angled



SM-68
Cleaning Bar



SM-69
Curved Head - Straight



SM-71
Latch Coupling - 35 mm



SM-70
Gun Buckle



SM-72
Latch Coupling - 25 mm



SM-73
Gun Buckle

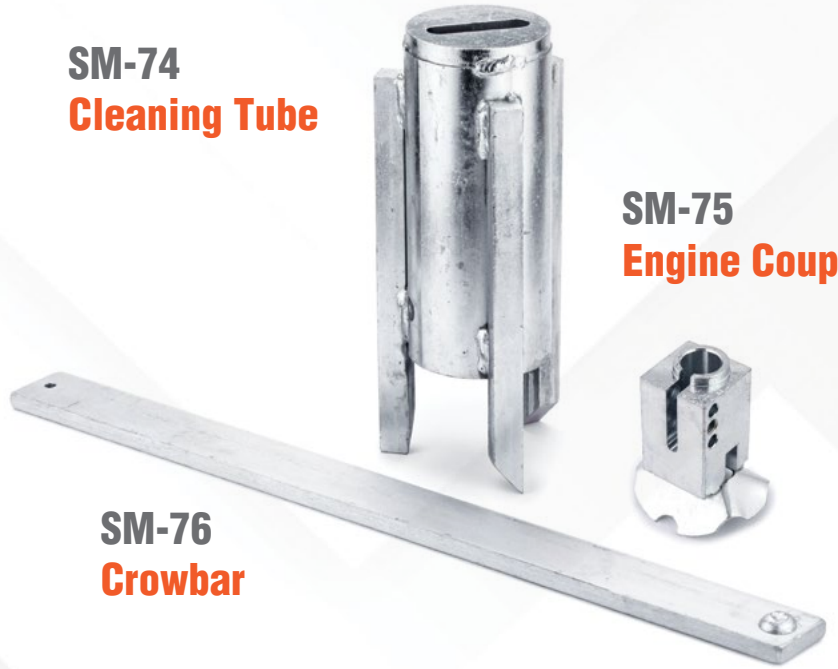

SM-74
Cleaning Tube

SM-76
Crowbar

SM-75
Engine Coupling



SM-77
Hose Ring



SM-78
Hose Record



SM-79
Lower Glange Record



SM-80
Hose - 25 mm / 15 mt



SM-81
Mixing Shaft



SM-82
Hose Record - Gear



SM-83
Coupling 1/1



SM-84
Coupling 1/1



SM-85
Coupling 1/2



SM-86
Coupling 1/2



SM-87
Plug



SM-88
Coupling - Water / 18 mm



SM-89
Coupling - Air / 12 mm



SMART
TECHNOLOGY

Yenibosna, Çobançeşme Mahallesi, Çardak Sokak, No:16/1
Bahçelievler - İstanbul / TÜRKİYE
spraytechh@gmail.com GSM: 0532 100 00 09